



Cambridge International Examinations
Cambridge Pre-U Certificate

GEOGRAPHY

9768/04

Paper 4 Research Topic

For Examination from 2016

SPECIMEN INSERT

1 hour 30 minutes

READ THESE INSTRUCTIONS FIRST

This Insert contains all the Figures and the Photograph referred to in the Question Paper.

The syllabus is approved for use in England, Wales and Northern Ireland as a Cambridge International Level 3 Pre-U Certificate.

This document consists of **11** printed pages and **1** blank page.

Fig. 1 for Question 1

Plant species along a woodland transect

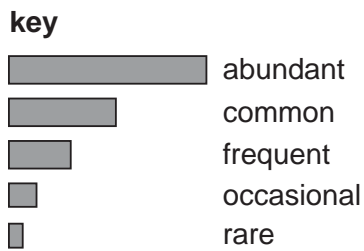
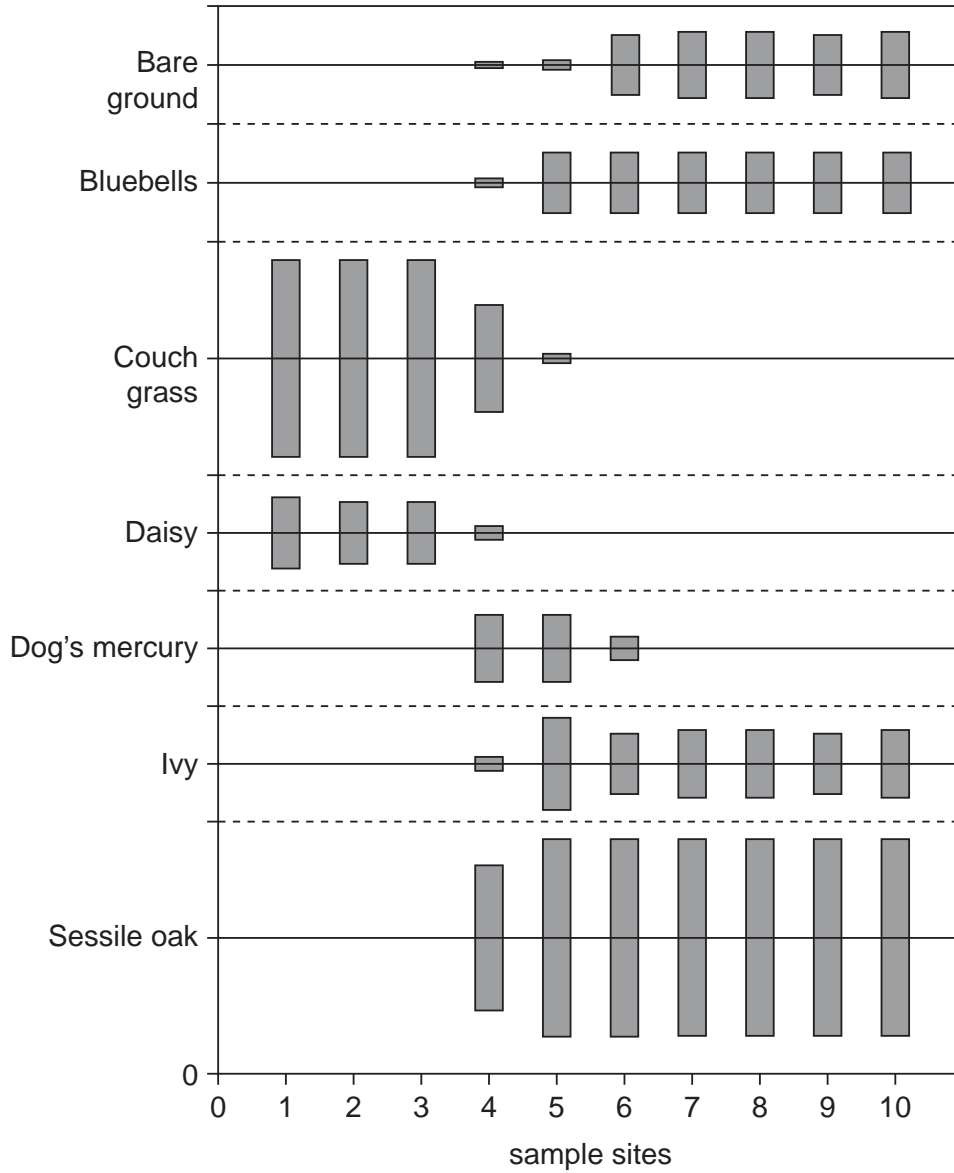

Fig. 2 for Question 1

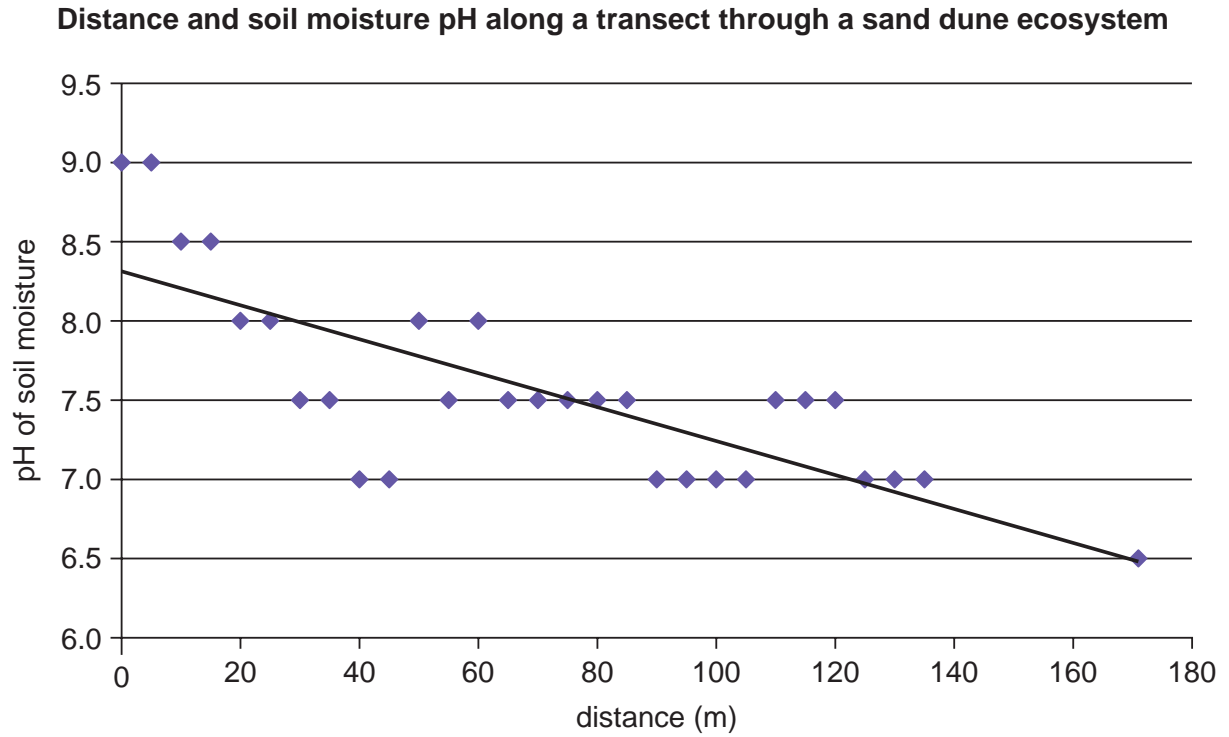
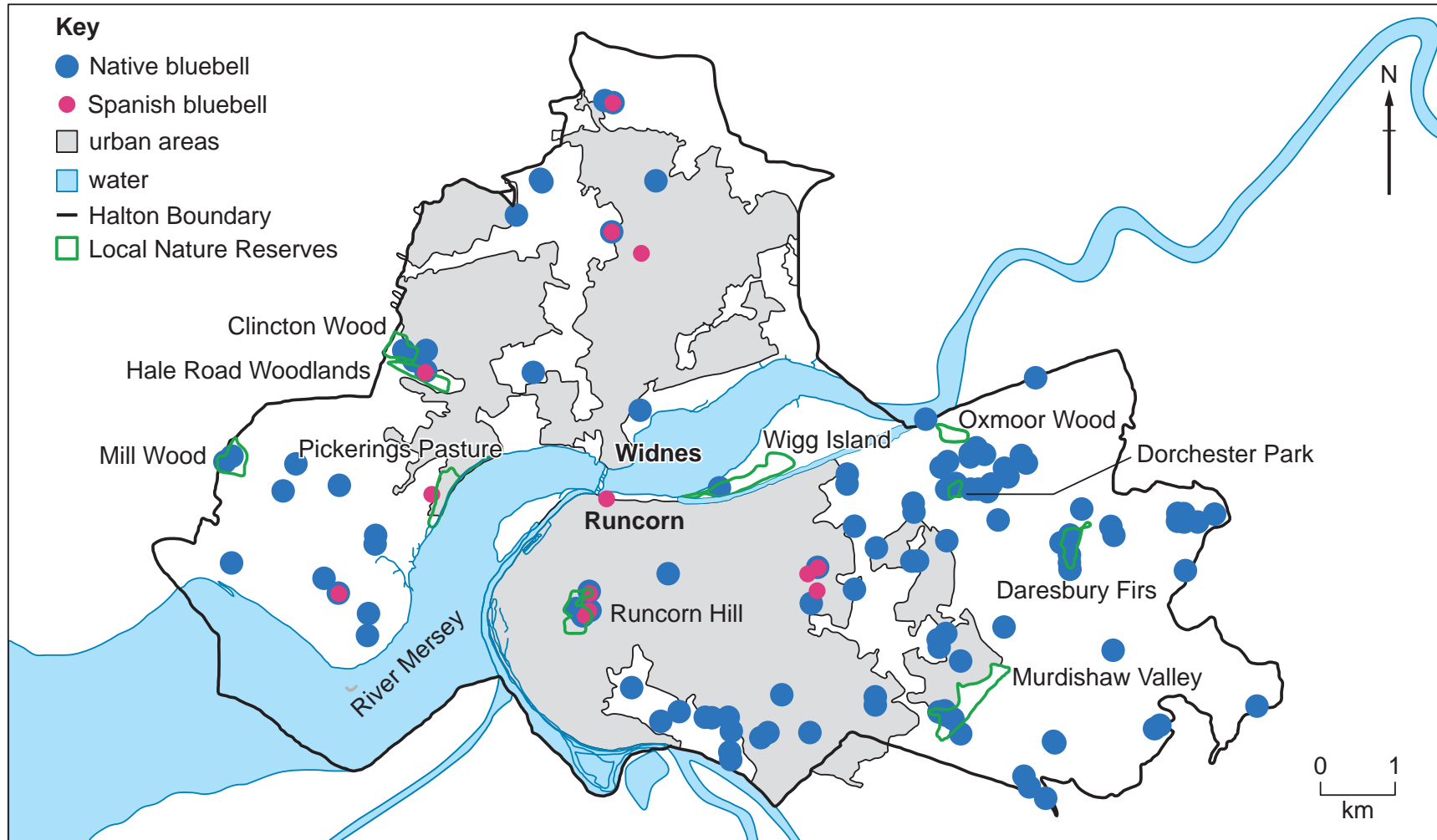

Fig. 3 for Question 2

Location of bluebells in the Borough of Halton, near Liverpool, England in 2007



BLANK PAGE

Fig. 4 for Question 5

Employment type in National Parks and in England and Wales, 2011

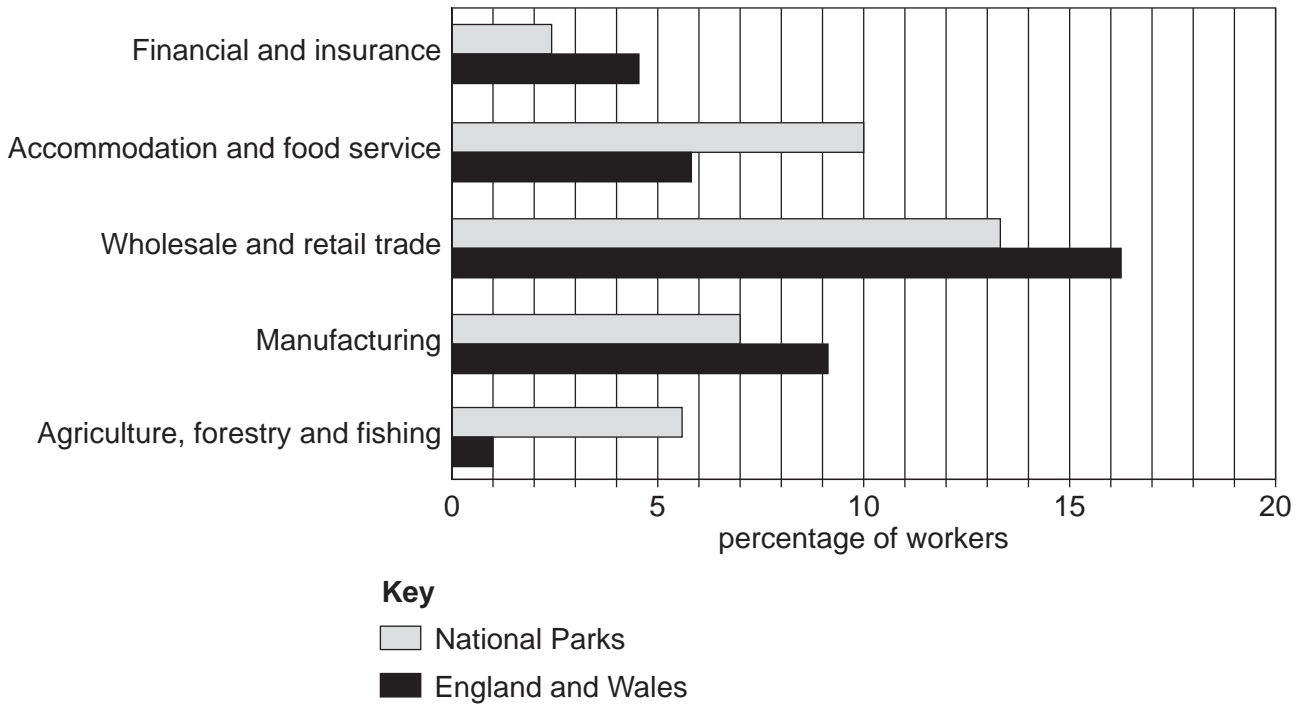

Fig. 5 for Question 5

Internal migration for rural and major urban areas, England, 2000 to 2010

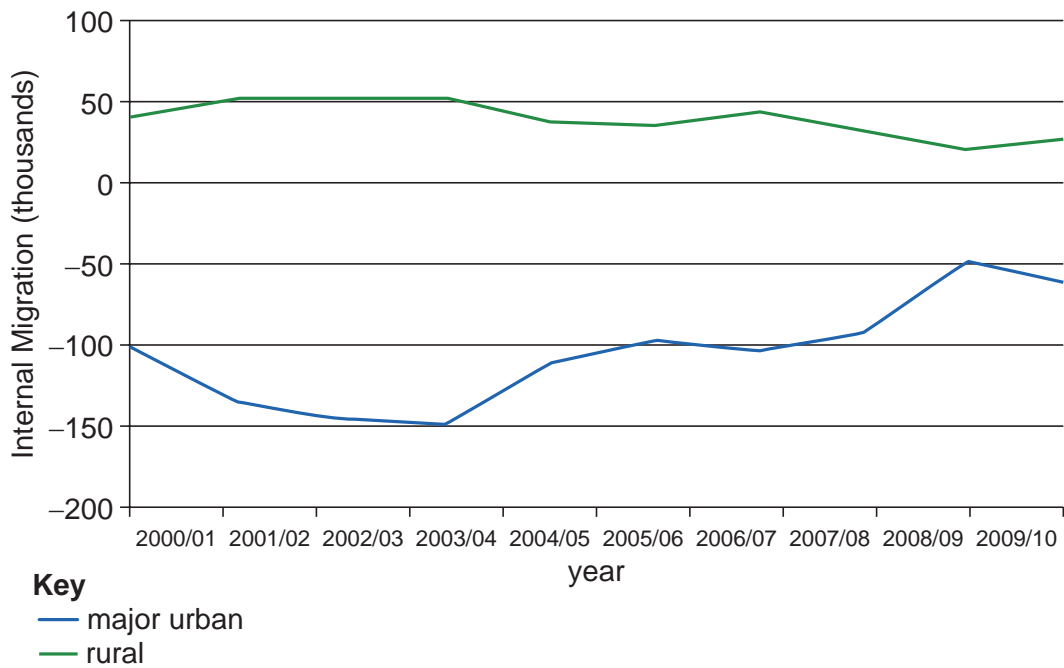

Fig. 6 for Question 5

Changes in population size by age for selected National Parks, England, 2001 to 2011

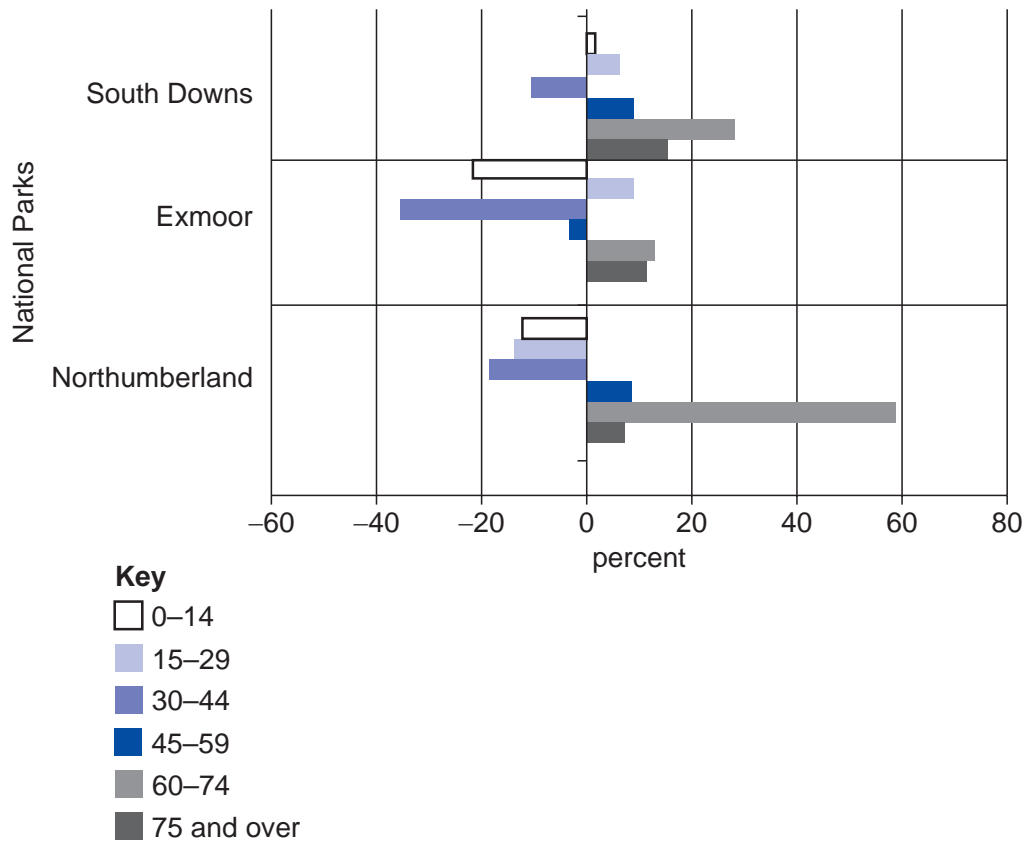
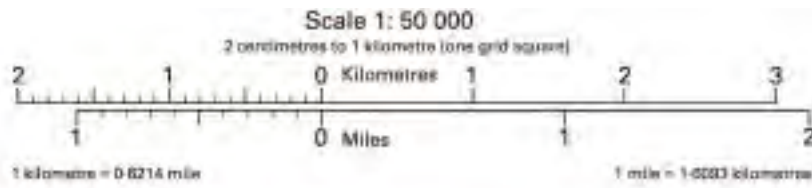

Fig. 7 for Question 6

1 : 50,000 OS map extract, SW Northumberland, England



Key for Fig. 7 [OS map]



ROADS AND PATHS

Not necessarily rights of way

- Secondary road
- Road generally more than 4m wide
- Road generally less than 4m wide
- Path / Other road, drive or track
- Gradient steeper than 20% (1 in 5), 14% to 20% (1 in 7 to 1 in 6)

RAILWAYS

- Viaduct, embankment

HEIGHTS

1 metre = 3.2808 feet

- Contours are at 10 metres vertical interval
 - Heights are to the nearest metre above mean sea level
- Where two heights are shown the first height is to the base of the triangulation pillar and the second (in brackets) to the highest natural point of the hill

ROCK FEATURES



TOURIST INFORMATION

- Camp site / caravan site
- Nature reserve
- Parking, Park and ride (all year / seasonal)
- Picnic site
- Selected places of tourist interest
- Viewpoint
- Visitor centre
- World Heritage site or area

LAND FEATURES

- Buildings
- Important building (selected)
- Triangulation pillar
- Coniferous wood
- National Trust (always open / limited access, observe local signs)

PUBLIC RIGHTS OF WAY

- Footpath
- Bridleway
- Byway open to all traffic

The symbols show the defined route so far as the scale of mapping will allow.
The representation on this map of any other road, track or path is no evidence of the existence of a right of way. Not shown on maps of Scotland

OTHER PUBLIC ACCESS

- On-road cycle route
- National Cycle Network number
- National Trail, European Long Distance Path, Long Distance Route, selected Recreational Routes

ABBREVIATIONS

- MS Milestone
- PC Public convenience (in rural areas)
- PH Public house

BOUNDARIES

- National Park

ANTIQUITIES

- Roman
- Non-Roman

Fig. 8 for Question 9

The relationship between river bed material and river channel pattern

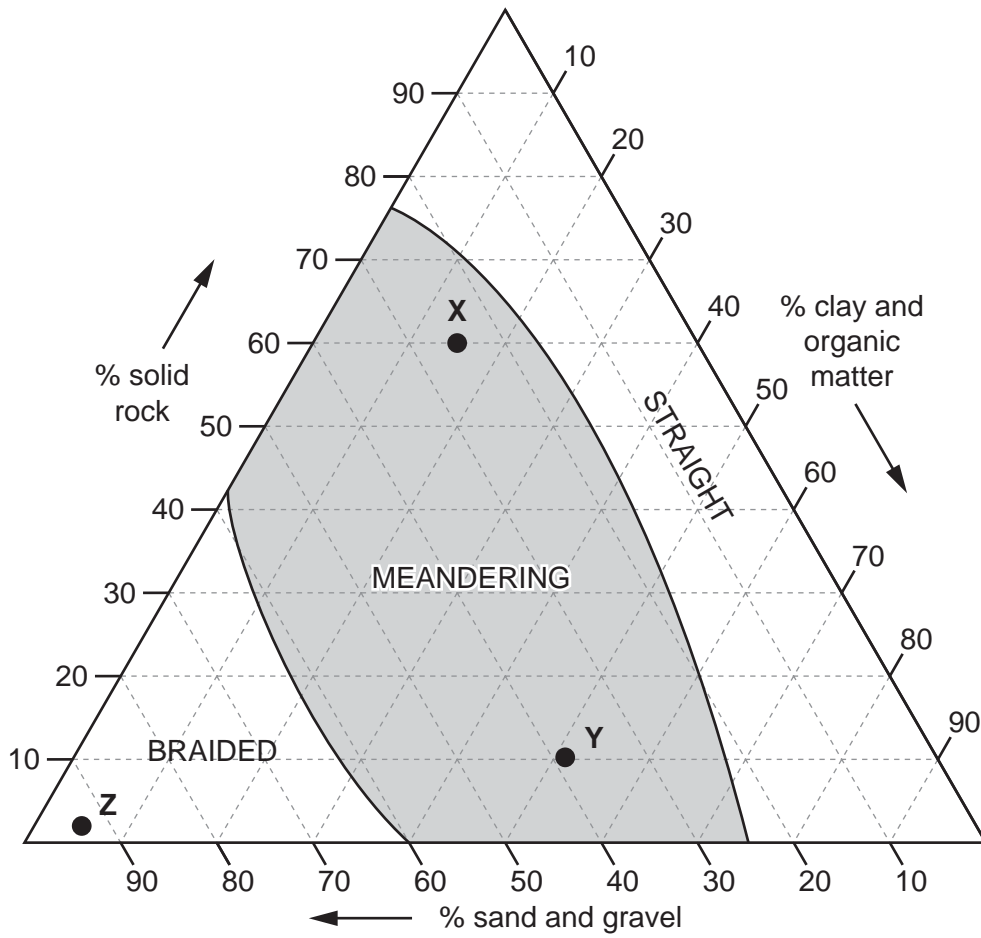

Key
 ● river

Fig. 9 for Question 9

1 : 50,000 OS map extract of the River Spey, Scotland

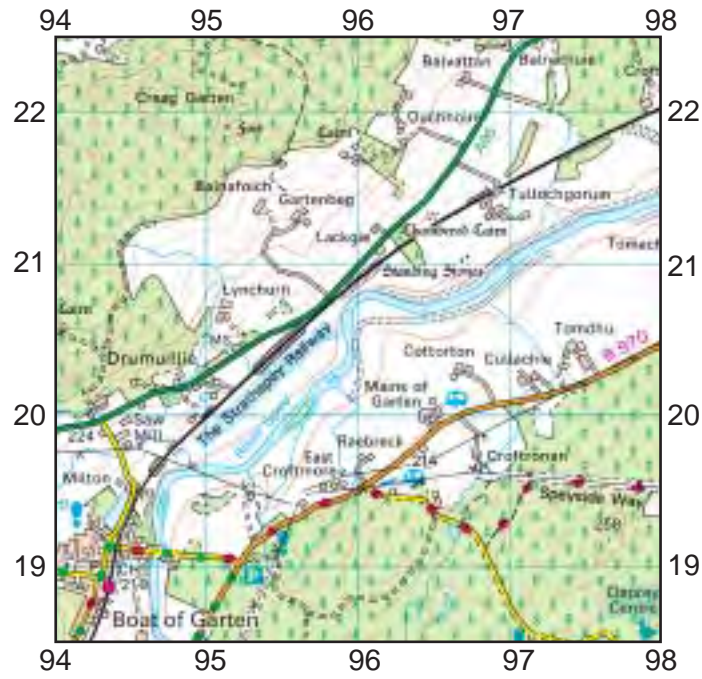

Photograph A for Question 9

Part of the River Spey shown on Fig. 9



Fig. 10 for Question 10

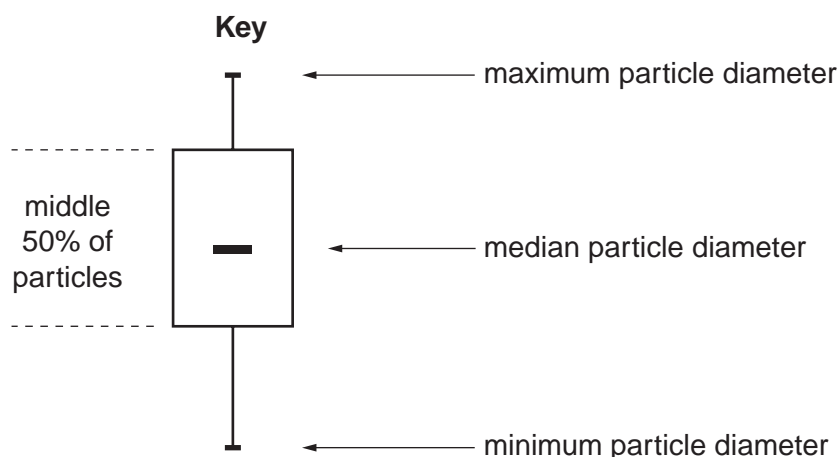
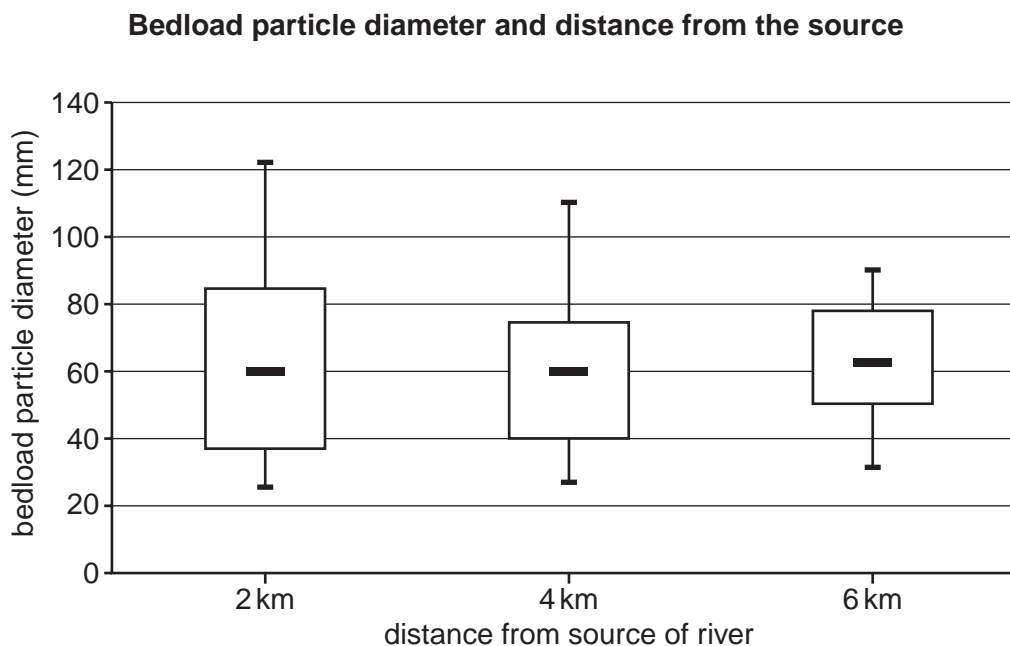

Copyright Acknowledgements:

- Question 1 Figure 1 © adapted: Alan Cadogan & Malcolm Ingram; *Maths for Advanced Biology*; Nelson Thornes Ltd; 2002.
 Question 2 Figure 3 © Dr Samantha Langdon; *Halton Bluebell Survey Report*; <http://www.record-lrc.co.uk/Downloads/bluebell%20project/WEB%20August%202007%20report.pdf>; 22 May 2013.
 Question 5 Figure 4 © *National Parks in England and Wales*; <http://youtube.com/watch?v=UnVxNzXggMQ>; 23 May 2013.
 Question 5 Figure 5 © *DEFRA statistical digest of rural England 2012*; https://www.gov.uk/government/uploads/system/uploads/attachment_data/file/69493/pb13642-rural-digest-2012.pdf; 23 May 2013.
 Question 5 Figure 6 © *Characteristics of National Parks*; Office for National Statistics; 23 May 2013.
 Question 6 Figure 7 © *Hexham and Haltwhistle*; OS Landranger 87; Ordnance Survey; 2009.
 Question 9 Figure 8 © K Hilton; *Process and Pattern in Physical Geography*; University Tutorial Press; 1985.
 Question 9 Figure 9 © *Extract of River Spey*; Ordnance Survey.
 Question 9 Figure 10 © *River Spey between Drumuillie and Culachie*; <http://www.multi-map.net/>.

Permission to reproduce items where third-party owned material protected by copyright is included has been sought and cleared where possible. Every reasonable effort has been made by the publisher (UCLES) to trace copyright holders, but if any items requiring clearance have unwittingly been included, the publisher will be pleased to make amends at the earliest possible opportunity.

Cambridge International Examinations is part of the Cambridge Assessment Group. Cambridge Assessment is the brand name of University of Cambridge Local Examinations Syndicate (UCLES), which is itself a department of the University of Cambridge.